

# ARENA

COMPOSITE CLADDING



## Cladding Installation Guide

### Contents

Important Note	2-4
Cladding Parts Overview	5
Cladding Parts Introductions	6
Tool List	6
Cladding Installation	7-11

## Important Note

---

The diagrams and instructions outlined in this guide are for illustrative purposes only and must comply with all local building regulations. The consumer assumes all risks and responsibilities associated with the construction and use of this product.

### Safety

Please take safety precautions before installing the cladding, check that the equipment is working properly and is free of malfunctions, and wear protective safety gear such as gloves, goggles, and impact resistant shoes.

### Environment

Proper installation requires a clean, smooth, and flat surface. Check with local building regulations before installing any type of cladding. If installation is not carried out within a timely manner following receipt of the composite cladding components, the components should be stored on a flat surface at all times. Never place on an uneven surface.

### Planning

Plan the layout for your cladding before you begin to ensure you get the best look for your cladding project. Check to see if any local authority building regulations are applicable (prior to any installation. We recommend planning the overall layout approach and scope of the layout prior to installation to try to avoid mistakes in this area.

### Heat and Fire

Excessive heat on the surface of Composite products from external sources such as, but not limited to fire or reflection of sunlight from energy efficient window products: Low-emissivity (Low-E) glass can potentially harm composite products. Low-E glass is designed to prevent passive heat gain within a structure and can cause unusual heat build-up on exterior surfaces. This extreme elevation of surface temperatures, which exceeds that of normal exposure, can possibly cause composite products to melt, sag, warp, discolour, increase expansion/contraction, and accelerate weathering.

### Fasteners

When fastening composite products all screws that are face fastened should always be driven in at a 90-degree angle to the cladding surface.

Toenailing/skew-screwing should never be used with composite cladding products. An extra batten should be added if a 90-degree angle cannot be driven into the board. All fasteners should be on their own independent batten, when two board ends meet each other there must be two battens side by side. The end of each board must sit on its own batten.

## Important Note

### Fasteners

Use white chalk, straight boards, or string lines as templates for straight lines. NEVER USE COLORED CHALK, Coloured chalk will permanently stain composite products and must not be used.

All screws that are face fixed should always be stainless steel. Depending on the screws that you use when face fixing, there could be potential bulging or mushrooming. It is recommended to take care of these mushrooms/bulges by taking a rubber mallet and patting them down to give a better look. If you need to replace the screws yourself, be sure to check first with your local hardware stores to see if they have screws that are engineered specifically for composite wood. These screws will ensure the correct results for composite cladding, using other screws that are not recommended for composite could potentially damage/harm the cladding.

### Pre-Drill

It is recommended to use an M4 (4mm) screw for face fixing the boards and the trims onto the batten. When face fixing, it is recommended to predrill a slightly bigger hole on the board and the trim to allow for expansion and contraction, as shown in the below diagram.

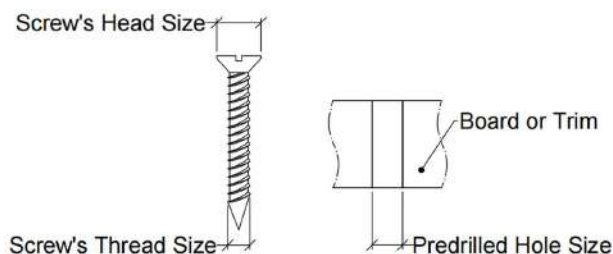

The predrilled hole size should be larger than the screw's thread size, from 1.5 mm to 2mm. Moreover, the predrilled hole size should also be smaller than the screw's head size, by at least 2mm. If this difference is less than 2mm a washer should be used.

### Batten Installation

A building professional should be consulted regarding vapor barriers and insulation for your project. Where a vapor barrier is to be used, it should be a breathable type and must be positioned behind the battens. The batten needs to have a minimum thickness of 30mm.

Use a suitable A4 Stainless Steel Countersunk Wood/Masonry screw to fix the batten to the wall. All battens need to be flat and levelled against the wall surface use shims/packers if necessary.

### Important Note

---





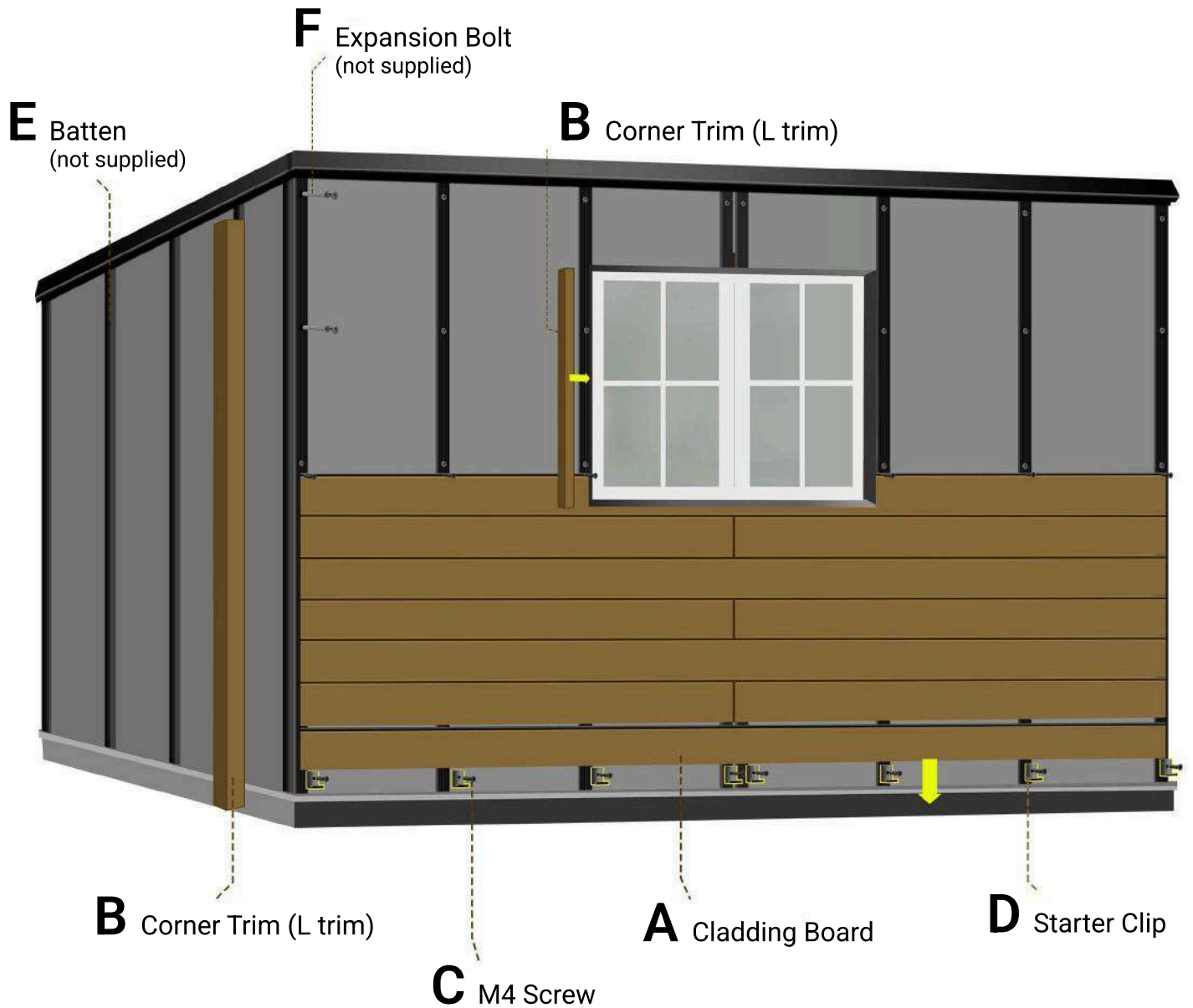

#### Expansion and Contraction Values

Composite boards will experience expansion and contraction with changes in temperature. Expansion and contraction are most significant where extreme temperature changes occur. The cladding boards should be fixed allowing for gaps as shown in the following table to allow for this movement.





### Cladding Parts Overview



## Cladding Parts Introduction

Product		Description
A		Cladding Board
B		External Corner Trim (L Trim)
C		M4 Screw
D		Starter Clip & Screw
E		Solid or Hollow Composite Batten
F		Expansion Bolts (not supplied)

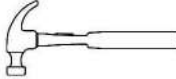
## Tool List

				
Electric Drill	Tape Measure	Hammer	Circular saw	Spirit Level

## Cladding Parts Installation Method

- 1 Place the first batten vertically along the bottom of the wall, use electric drill to punch holes on the wall at every 500mm, then use hammer to tap the expansion pipe into the hole and fix it with screw. Install the remaining battens on the wall with the same method, with a spacing of 500mm between each two adjacent battens.

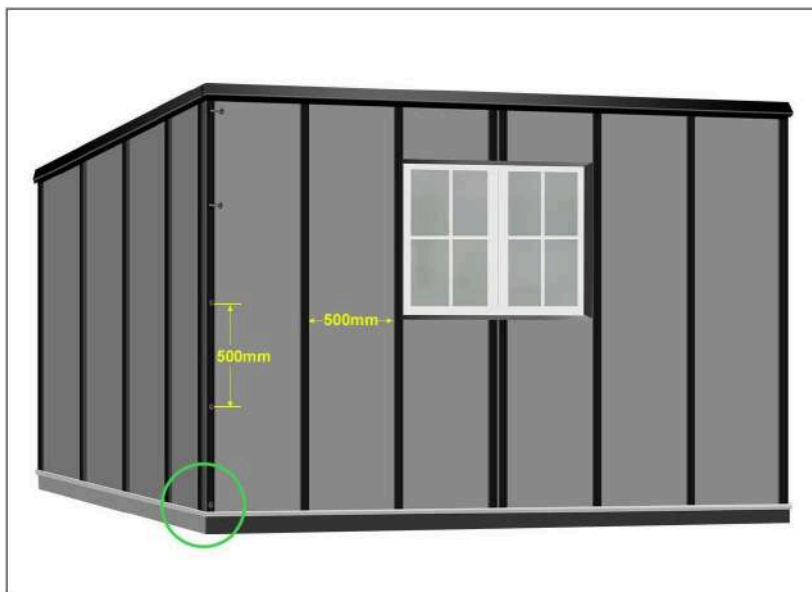

### Notes

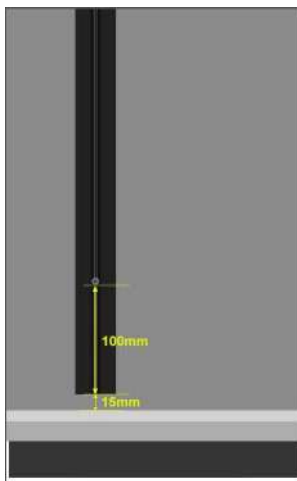

A gap of 15mm is reserved between the bottom end of the batten and the ground. The fixed position of the first expansion screw is 100mm away from the lower end of the batten.

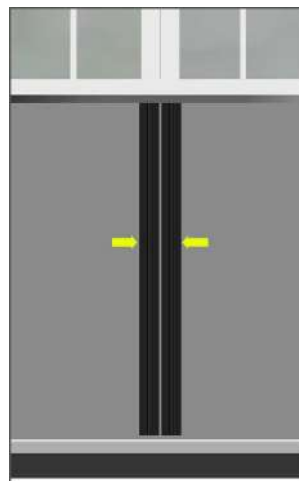

When there are windows on the wall, remember to install two pieces of batten under the windows.

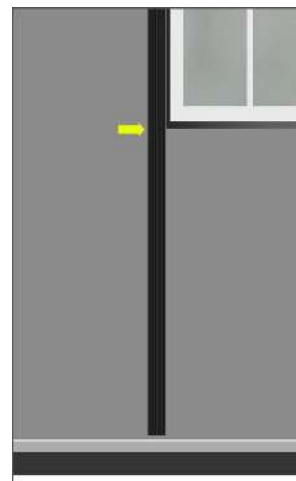

Making sure there is a batten next to the window side.

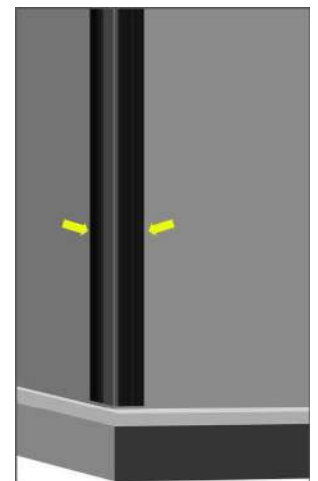

Double batten for the corner.

- 2 Pre-drill hole on the batten and install the starter clip with screw at a distance of 35 mm from the lower end of the batten. Keep the lower end of the cladding board align with the bottom of the batten, and then install the rest starter clips in the same way.

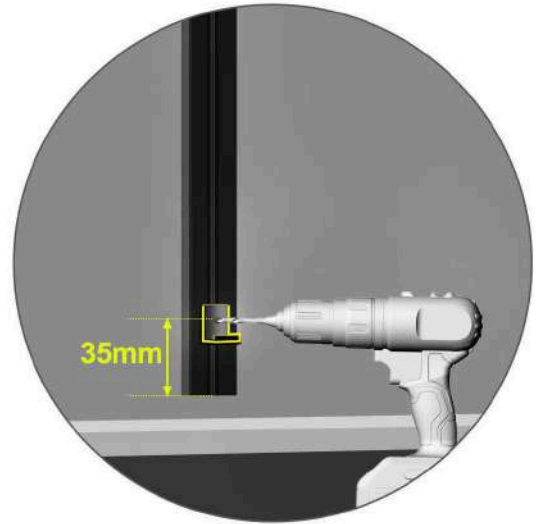
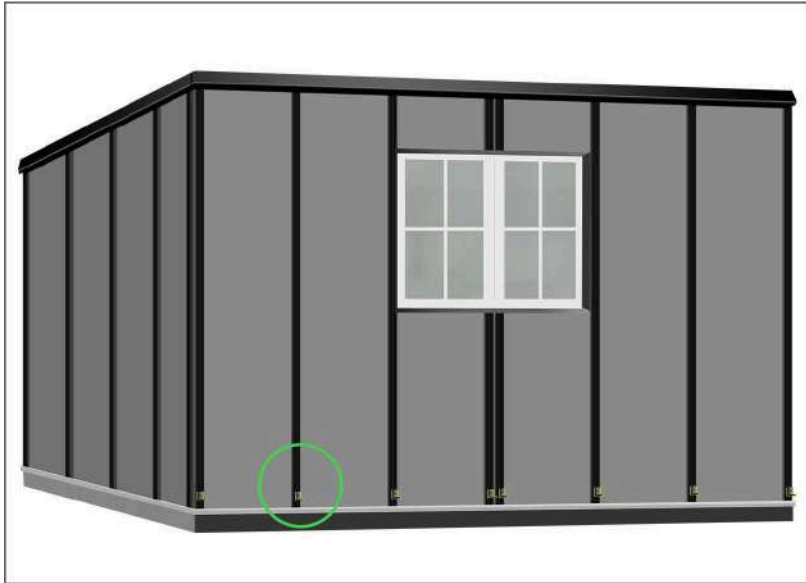

- 3 After installation of all the starter clips, insert the first cladding board into the clips, then fix the cladding board with screws by using electric drill.

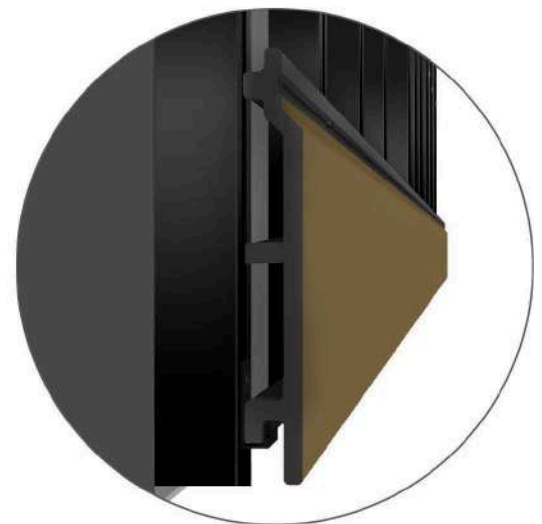
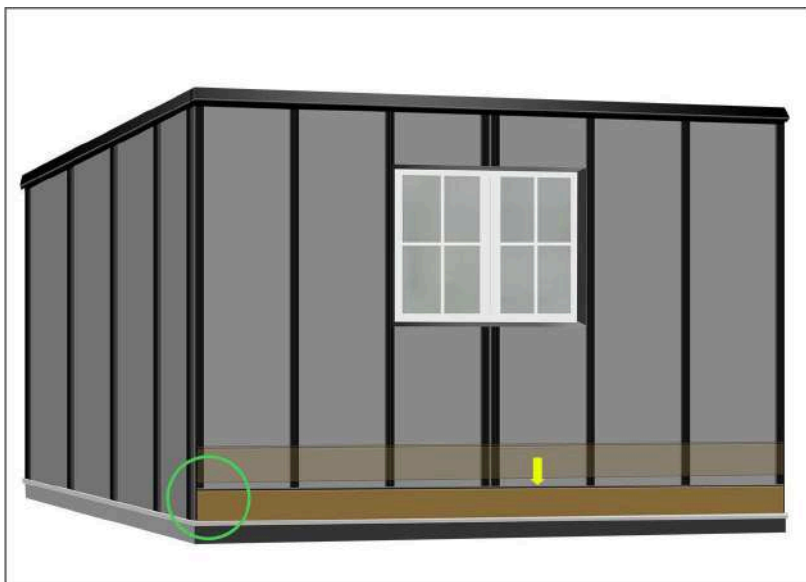

- Continue to install the remaining cladding boards, make sure the edges of cladding board overlap each other.

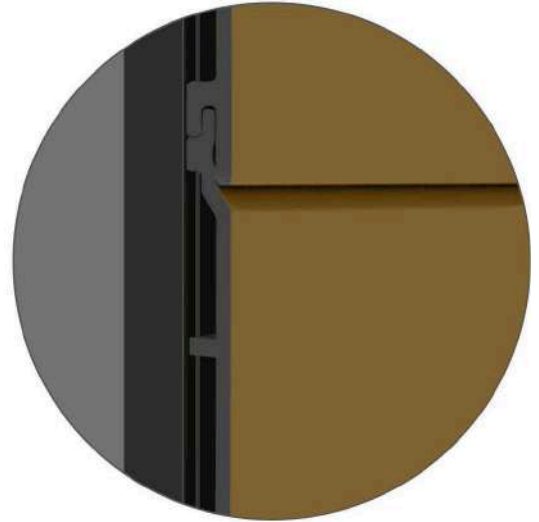
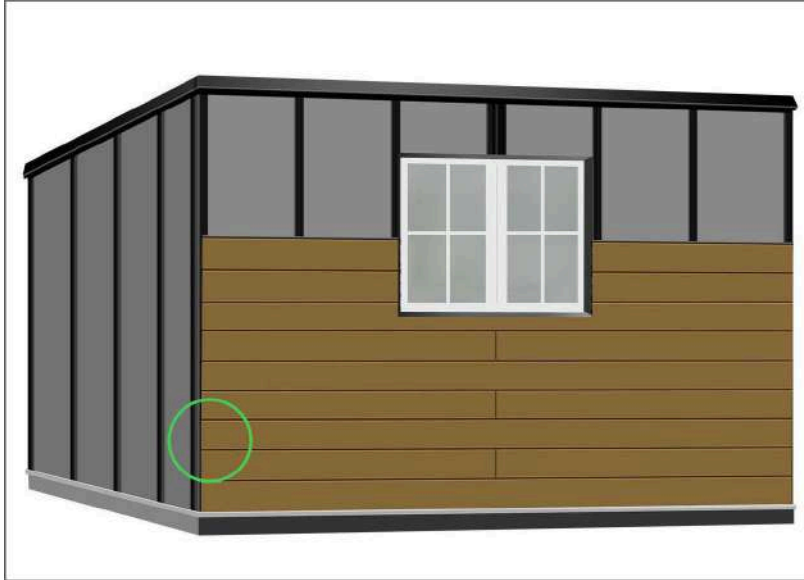

### Notes

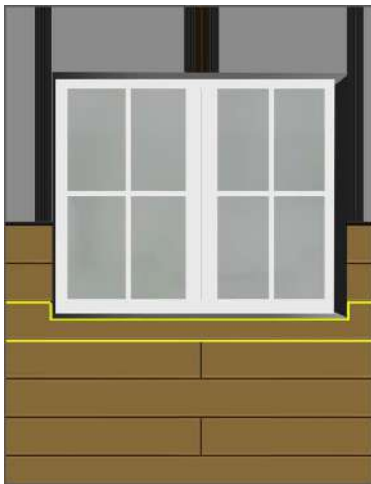

When meet window areas. Cut appropriate cladding board size to fit the window area.

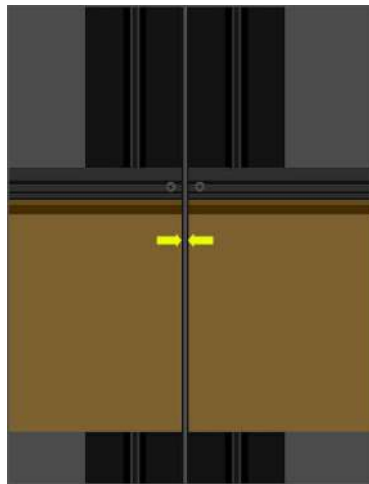

Remain at least 3mm gap between board connection.

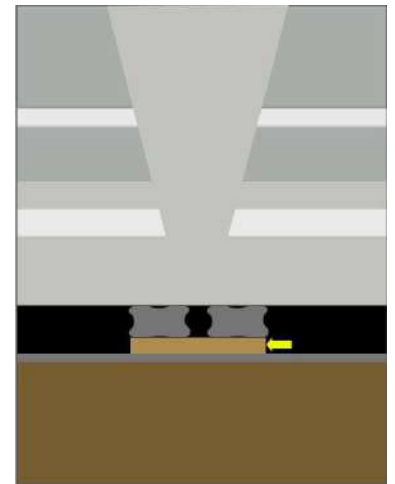

Put a small piece of wood between the batten and the cladding on the top and bottom of the window.

- 5 Cut L-trim to appropriate size and make sure all the trim ends be cut at a 45° angle. Secure them to the exposed corners of the window, making sure the exposed edges of the cladding panels are properly covered.

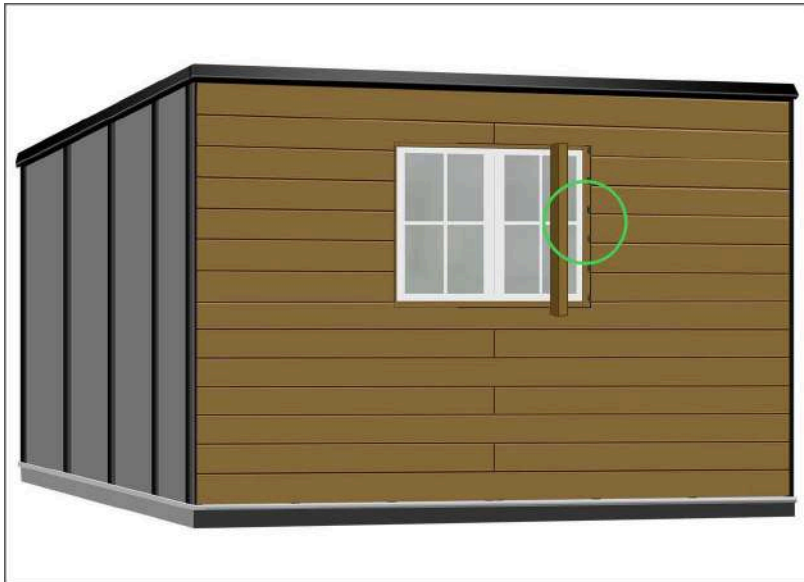

- 6 Continue to install cladding board line by row until the entire wall is covered. Trim the last row of cladding boards, install L-trim in the corners with screw, which will help you cover the ends of the cladding boards and protect against water and insects.

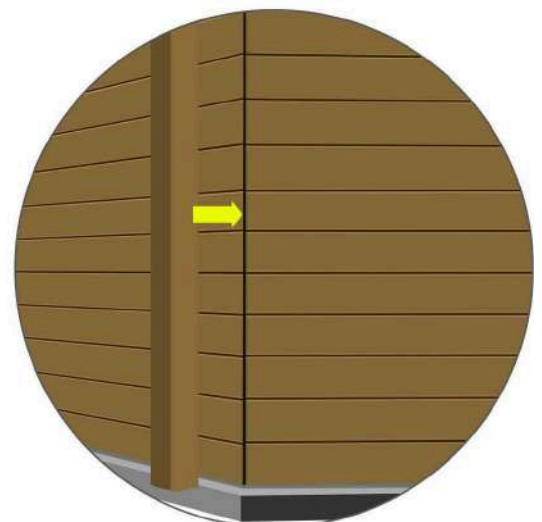
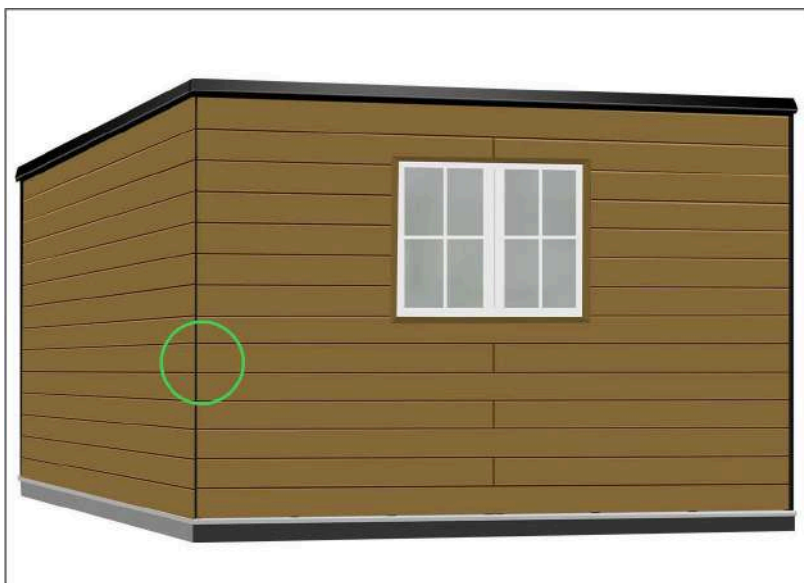

### Finished Overview

