

ARENA

COMPOSITE CLADDING



Cladding Installation Guide

Contents

Important Note	2-4
Cladding Parts Overview	5
Cladding Parts Introductions	6
Cladding Parts Installation Method	7-13

Important Note

The diagrams and instructions outlined in this guide are for illustrative purposes only and must comply with all local building regulations. The consumer assumes all risks and responsibilities associated with the construction and use of this product.

Safety

Please take safety precautions before installing the cladding, check that the equipment is working properly and is free of malfunctions, and wear protective safety gear such as gloves, goggles, and impact resistant shoes.

Environment

Proper installation requires a clean, smooth, and flat surface. Check with local building regulations before installing any type of cladding. If installation is not carried out within a timely manner following receipt of the composite cladding components, the components should be stored on a flat surface at all times. Never place on an uneven surface.

Planning

Plan the layout for your cladding before you begin to ensure you get the best look for your cladding project. Check to see if any local authority building regulations are applicable (prior to any installation. We recommend planning the overall layout approach and scope of the layout prior to installation to try to avoid mistakes in this area.

Heat and Fire

Excessive heat on the surface of Composite products from external sources such as, but not limited to fire or reflection of sunlight from energy efficient window products: Low-emissivity (Low-E) glass can potentially harm composite products. Low-E glass is designed to prevent passive heat gain within a structure and can cause unusual heat build-up on exterior surfaces. This extreme elevation of surface temperatures, which exceeds that of normal exposure, can possibly cause composite products to melt, sag, warp, discolour, increase expansion/contraction, and accelerate weathering.

Fasteners

When fastening composite products all screws that are face fastened should always be driven in at a 90-degree angle to the cladding surface.

Toenailing/skew-screwing should never be used with composite cladding products. An extra batten should be added if a 90-degree angle cannot be driven into the board. All fasteners should be on their own independent batten, when two board ends meet each other there must be two battens side by side. The end of each board must sit on its own batten.

Important Note

Fasteners

Use white chalk, straight boards, or string lines as templates for straight lines. NEVER USE COLORED CHALK, Coloured chalk will permanently stain composite products and must not be used.

All screws that are face fixed should always be stainless steel. Depending on the screws that you use when face fixing, there could be potential bulging or mushrooming. It is recommended to take care of these mushrooms/bulges by taking a rubber mallet and patting them down to give a better look. If you need to replace the screws yourself, be sure to check first with your local hardware stores to see if they have screws that are engineered specifically for composite wood. These screws will ensure the correct results for composite cladding, using other screws that are not recommended for composite could potentially damage/harm the cladding.

Pre-Drill

It is recommended to use an M4 (4mm) screw for face fixing the boards and the trims onto the batten. When face fixing, it is recommended to predrill a slightly bigger hole on the board and the trim to allow for expansion and contraction, as shown in the below diagram.

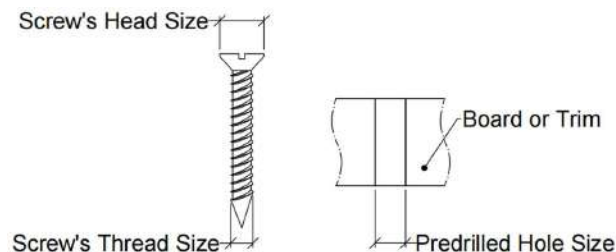

The predrilled hole size should be larger than the screw's thread size, from 1.5 mm to 2mm. Moreover, the predrilled hole size should also be smaller than the screw's head size, by at least 2mm. If this difference is less than 2mm a washer should be used.

Batten Installation

A building professional should be consulted regarding vapor barriers and insulation for your project. Where a vapor barrier is to be used, it should be a breathable type and must be positioned behind the battens. The batten needs to have a minimum thickness of 30mm.

Use a suitable A4 Stainless Steel Countersunk Wood/Masonry screw to fix the batten to the wall. All battens need to be flat and levelled against the wall surface use shims/packers if necessary.

Important Note

Expansion and Contraction Values



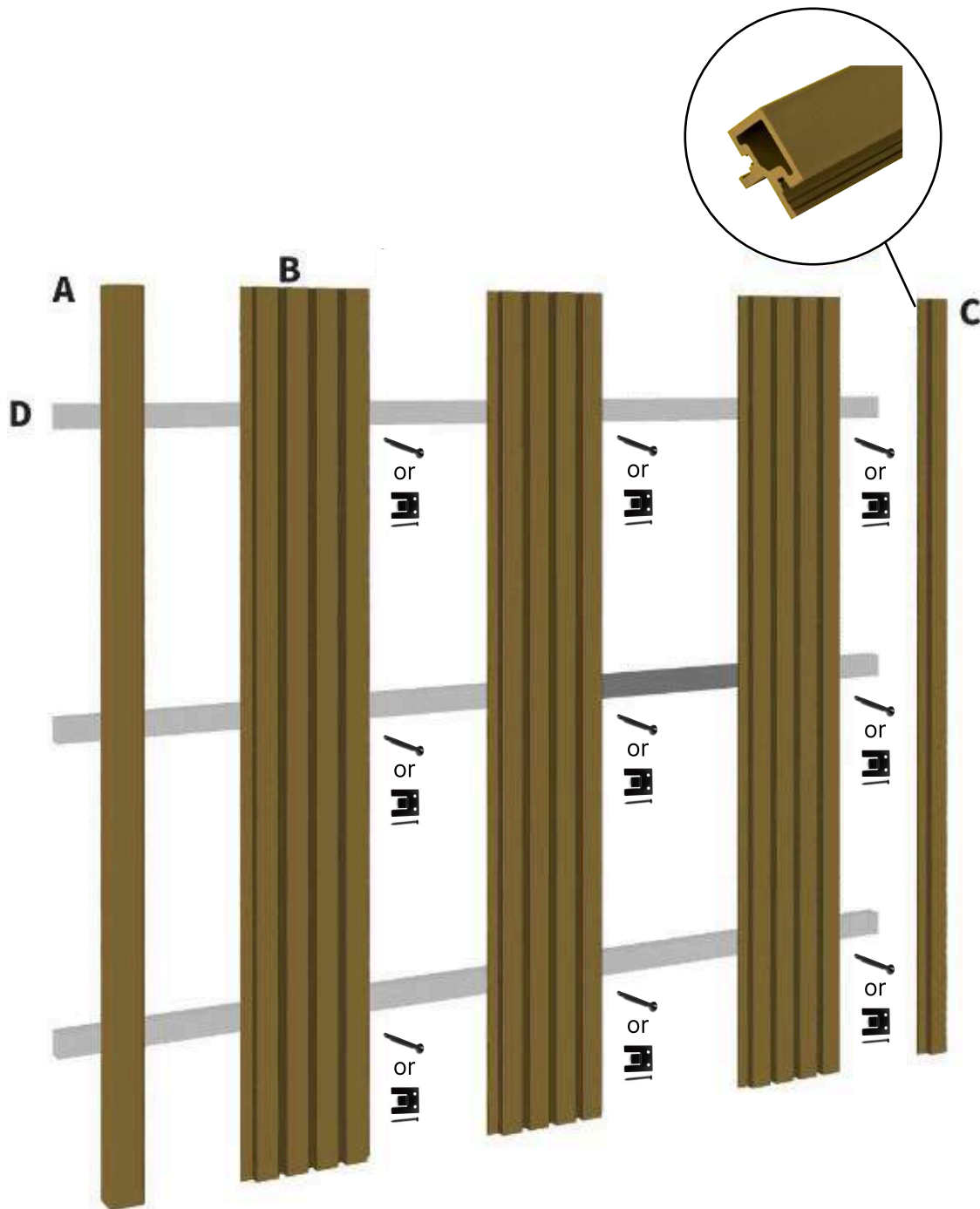

Composite boards will experience expansion and contraction with changes in temperature. Expansion and contraction are most significant where extreme temperature changes occur. The cladding boards should be fixed allowing for gaps as shown in the following table to allow for this movement.

		Length (m)								Gap (mm)
		1	2.44	2.8	3	3.66	3.9	4	4.88	
Ambient Temperature (Degrees C)	32	1.6	3.2	3.2	4.8	4.8	6.4	6.4	7.9	
	41	1.6	3.2	3.2	3.2	4.8	4.8	6.4	6.4	
	50	1.6	3.2	3.2	3.2	3.2	4.8	4.8	4.8	
	59	1.6	1.6	1.6	3.2	3.2	3.2	3.2	4.8	
	68	1.2	1.6	1.6	1.6	1.6	3.2	3.2	3.2	
	77	1.2	1.6	1.6	1.6	1.6	1.6	1.6	1.6	
	86	1.2	1.2	1.2	1.2	1.2	1.6	1.6	1.6	





Cladding Parts Overview

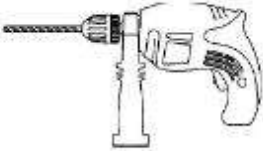

Cladding Parts Introduction

Product		Description
A		End Cover
B		Cladding Panel
C		External Corner Trim
D		Solid or Hollow Composite Batten
E		Screw
F		Starter Clip & Screw
G		Installation Clip

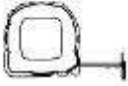
Tool List

				
Impact Drill	Electric Drill	Tape Measure	Hammer	Spirit Level

Cladding Parts Installation Method

- 1 Install battens onto wall at 500mm intervals between adjacent battens. The topmost batten should be positioned 10mm from the top of the wall (see Detail 1-1) and the bottom batten 20mm from the floor (see Detail 1-2). Secure the battens to the wall with screws at 500mm centres. Fix the Cladding Starter Screws if using so the cladding sits over the clips.

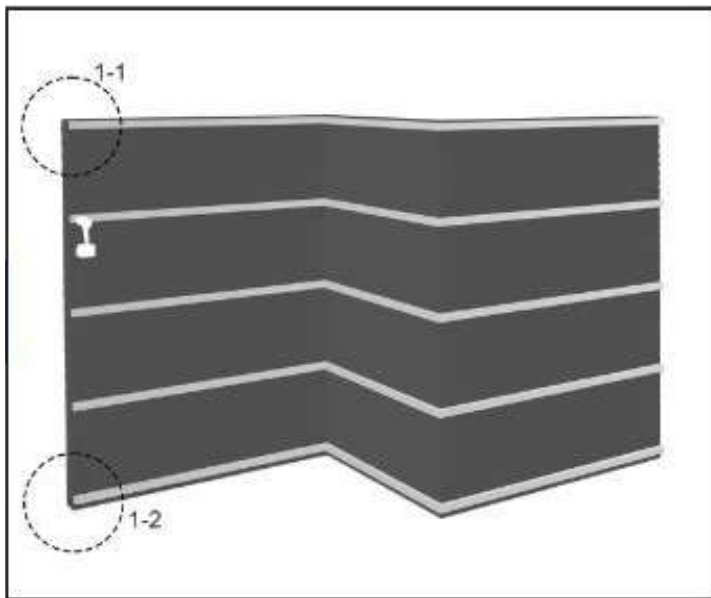

Diagram 1

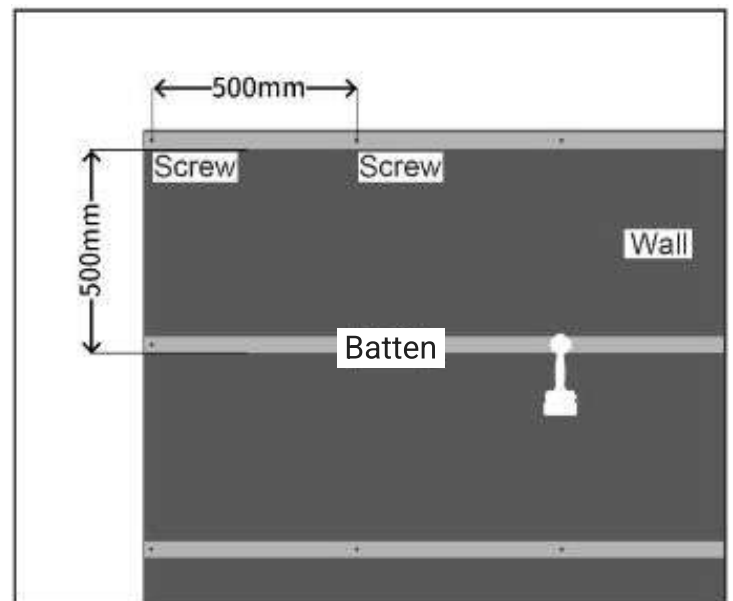
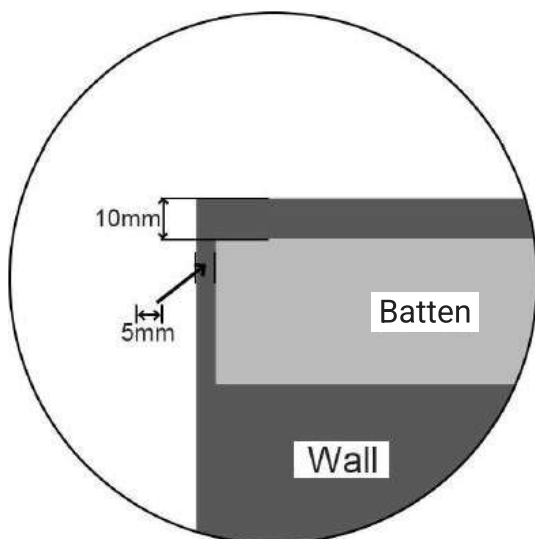
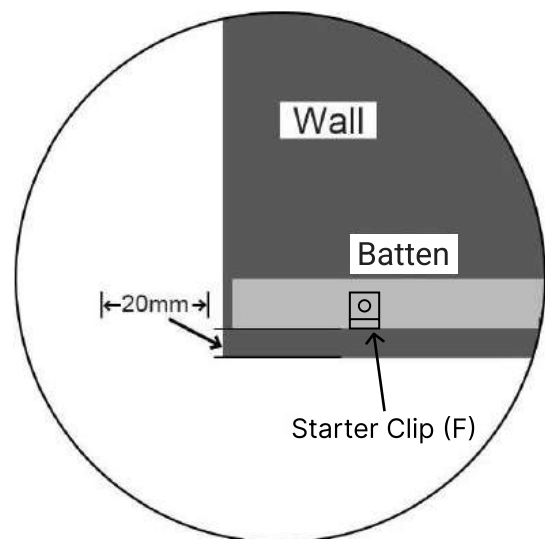

Diagram 2



Detail 1-1



Detail 1-2

- 2 Place cladding panel in line with the edge of the battens. Pre-drill and screw the cladding to each batten (see Detail 3-1).

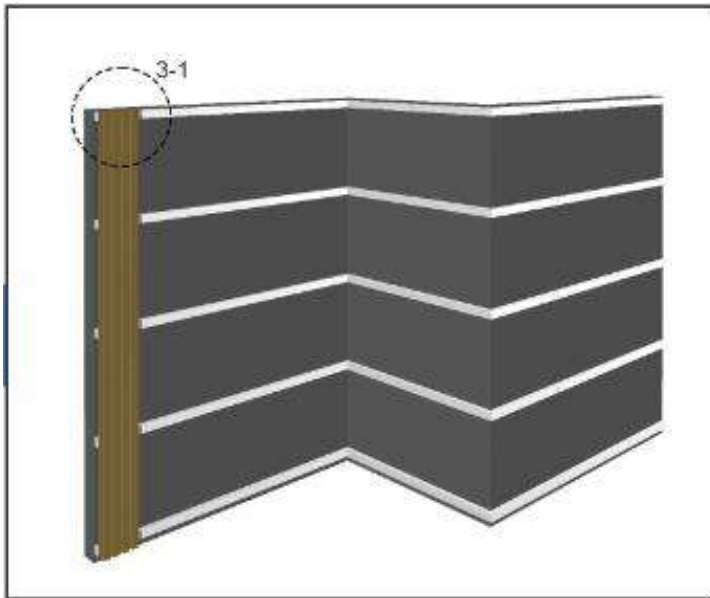
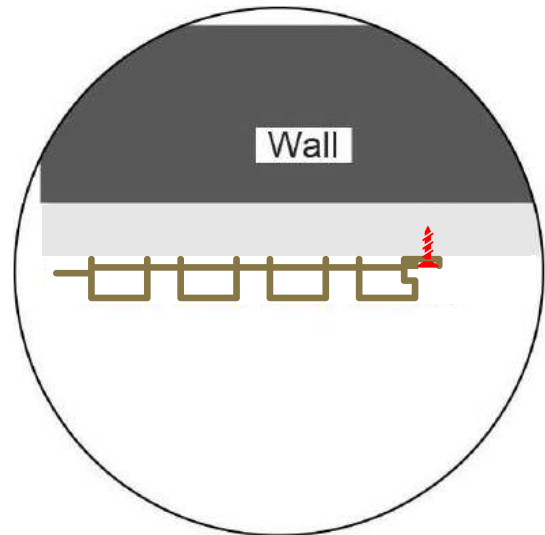

Diagram 3



Detail 3-1

- 3 Insert the next cladding panel into the first panel, ensuring correct location positioning and pre-drill and screw the cladding to each batten (see Detail 4-1). Repeat this process until the remaining wall is too narrow for a full panel.

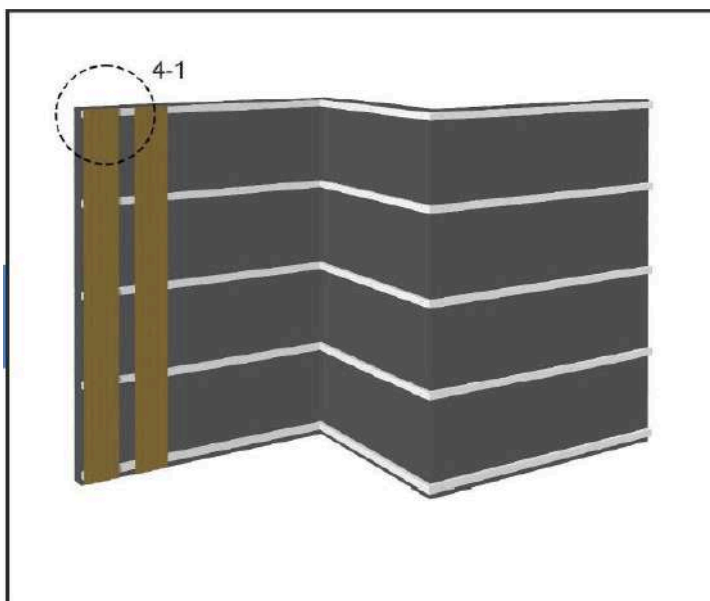
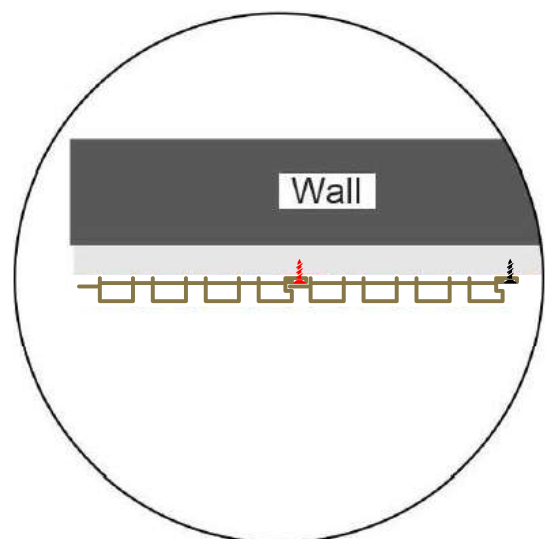

Diagram 4



Detail 4-1

- 4 Measure the distance from the last cladding panel to the corner and mark it as 'a' mm. Cut a cladding panel from the insert side to fit the measured distance.

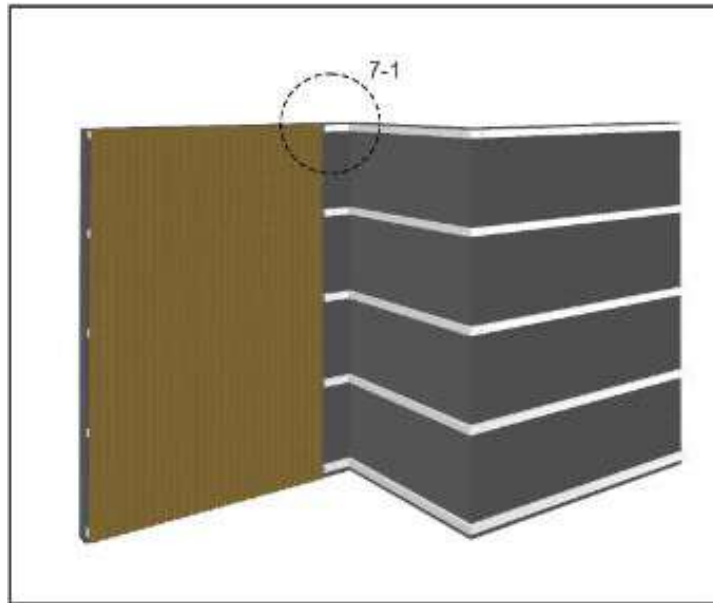
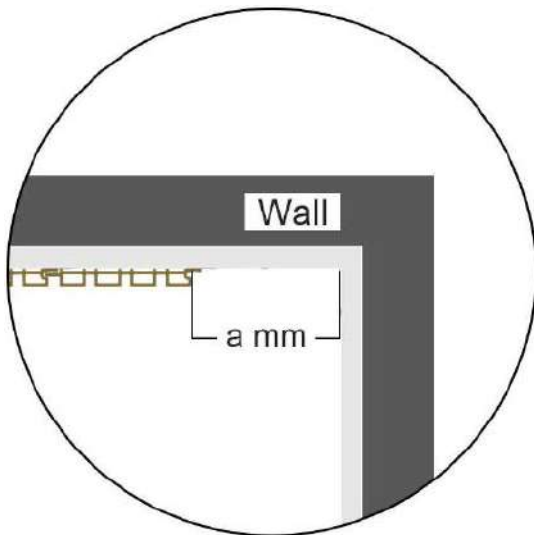
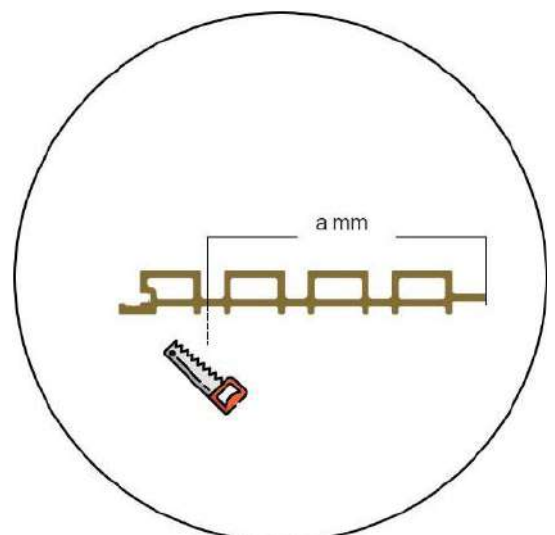

Diagram 5



Detail 5-1



Detail 5-2

- 5 Screw the cut-out cladding panel to the batten at the nearest groove to the corner. (For better screwing effect, use rubber stoppers where the cladding panel meets the top and bottom battens).

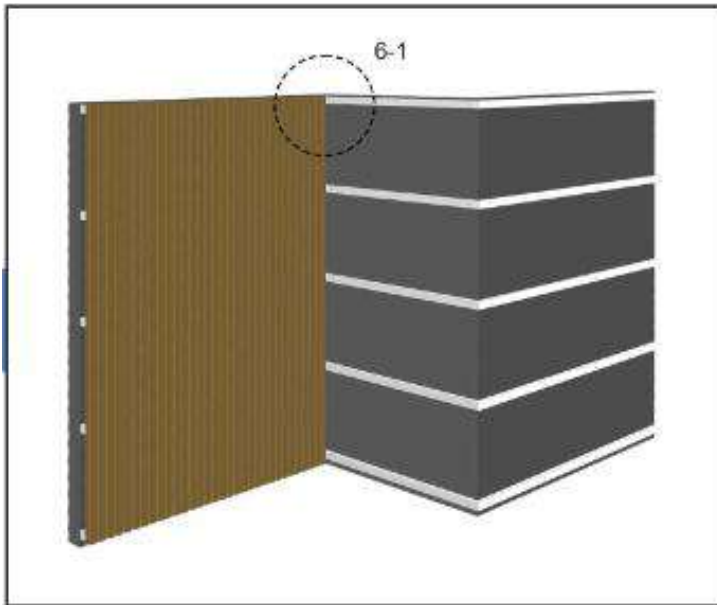
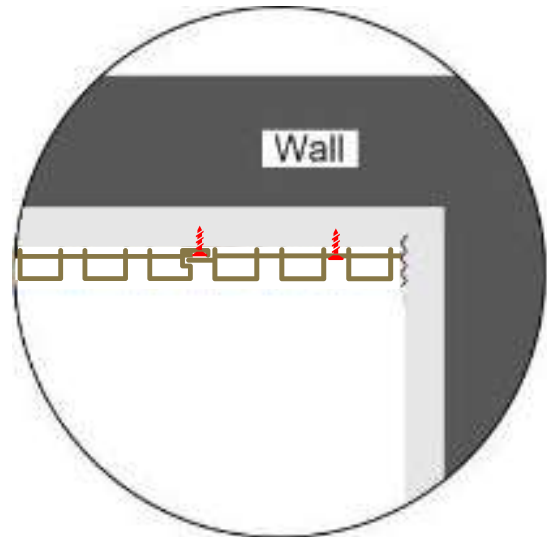

Diagram 6



Detail 6-1

- 6 Install the corner trim to the corner with screws (see Detail 7-1).

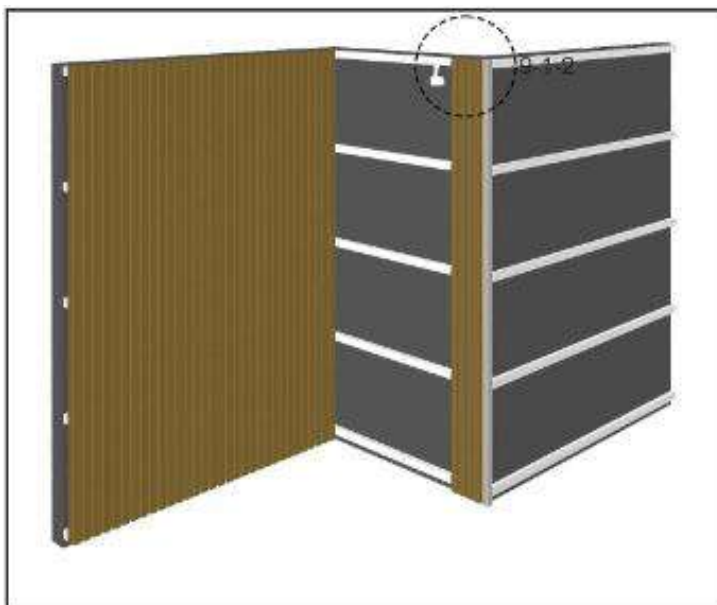
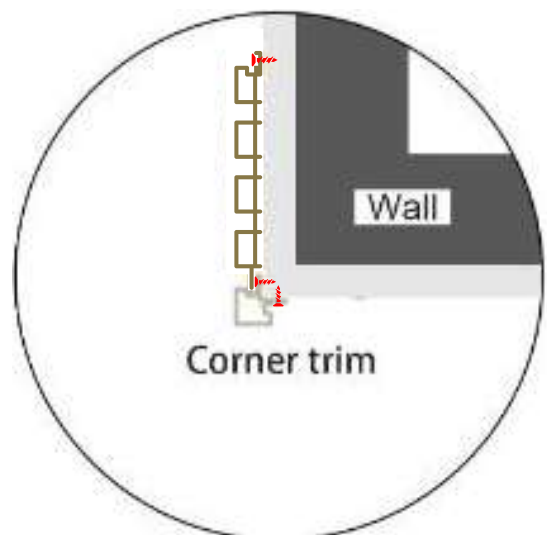

Diagram 7



Detail 7-1

- 7 Continue installing connector clips and cladding panels sequentially until the remaining wall width is too narrow for a full panel. Measure the remaining wall width and cut a cladding panel to fit.

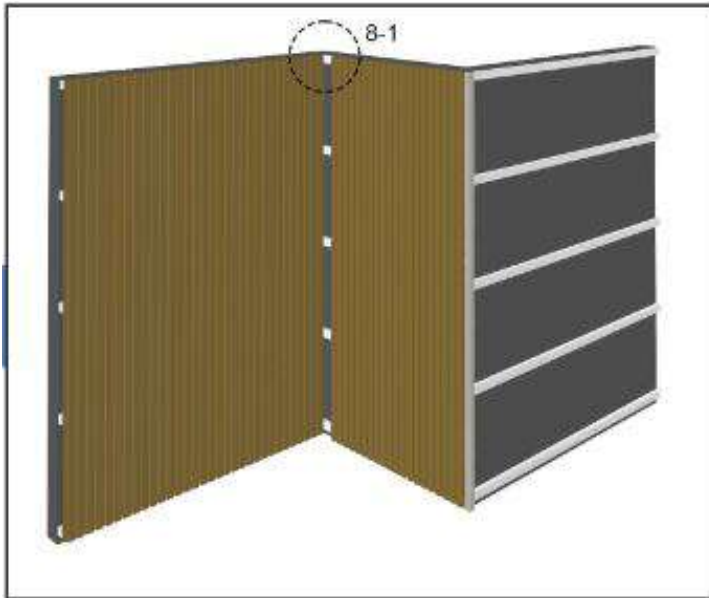
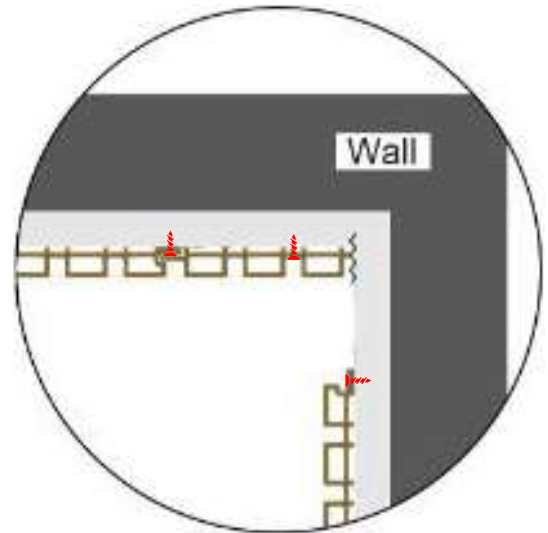

Diagram 8



Detail 8-1

- 8 Screw the cut-out cladding panel to the battens at the nearest grooves to the corner.

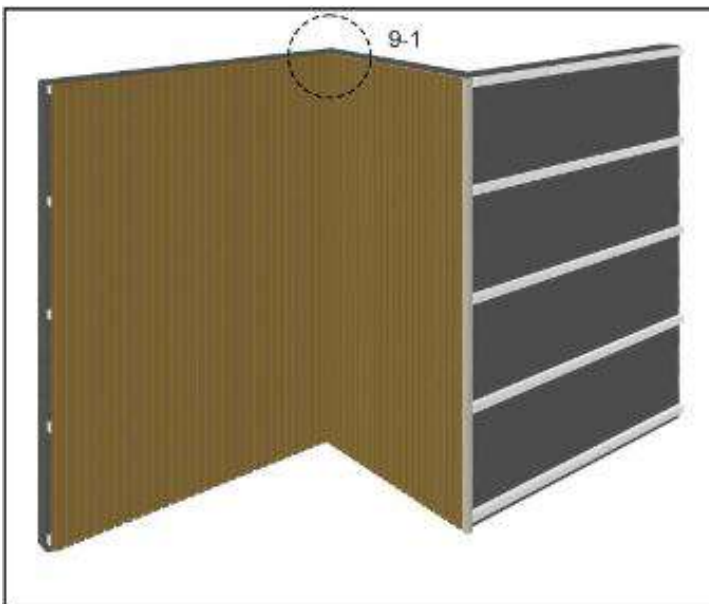
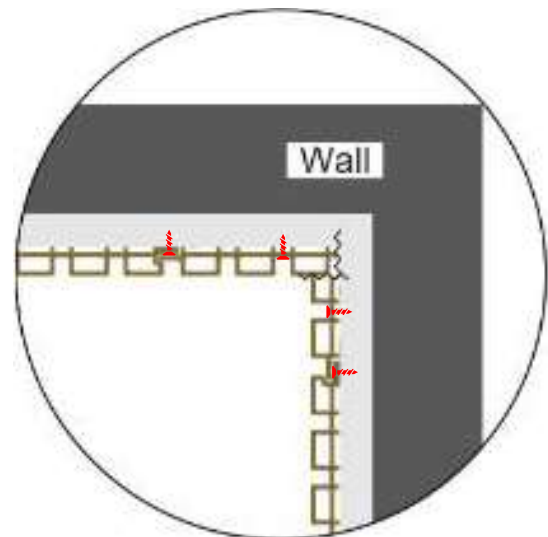

Diagram 9



Detail 9-1

- 9 Continue installing cladding panels and connector clips on the other side of the corner trim until the remaining wall width is too narrow for a full panel. Measure the remaining wall width and cut a cladding panel to fit. Then install the cladding panel onto the battens (see Detail 10-1).

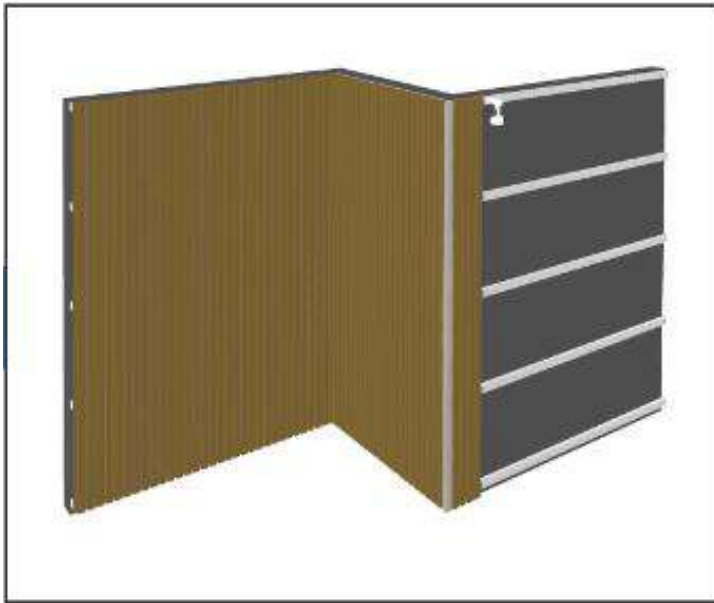

Diagram 10

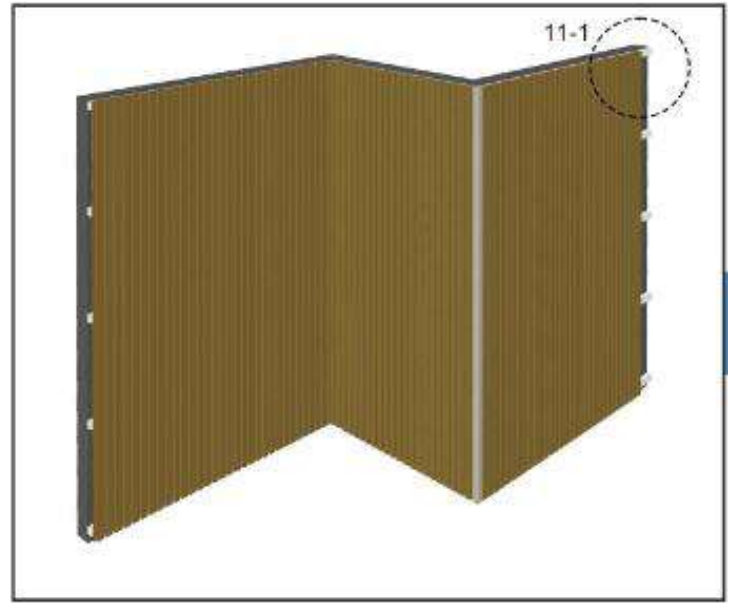
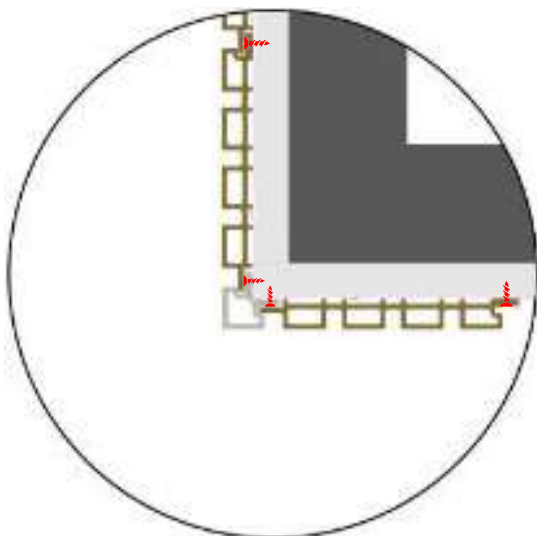
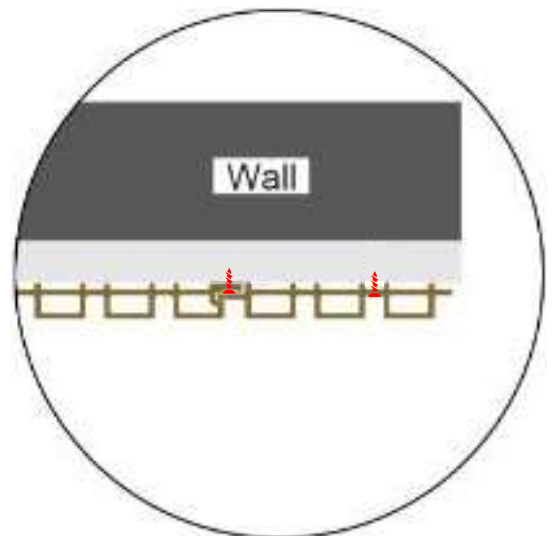

Diagram 11



Detail 10-1



Detail 11-1

- Put end covers on both sides of the wall cladding project and secure them to the cladding panels and battens with screws. (For better screwing effect, use rubber stoppers where the trimmer meets the batten).

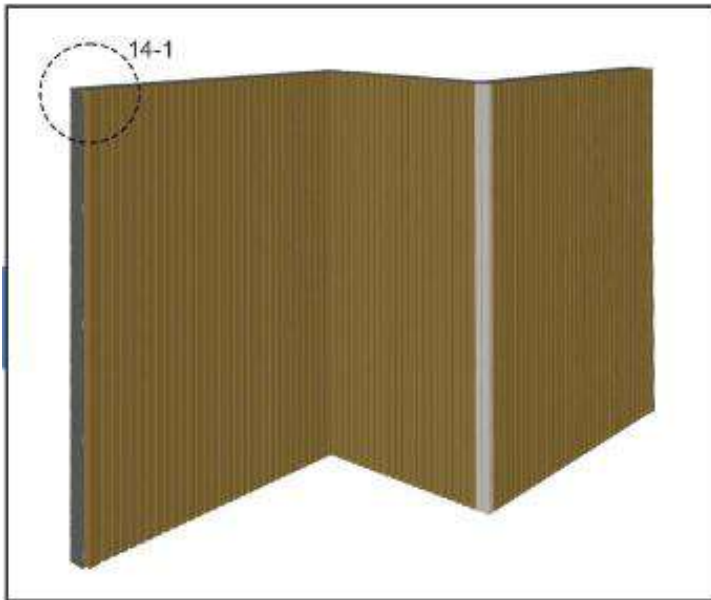
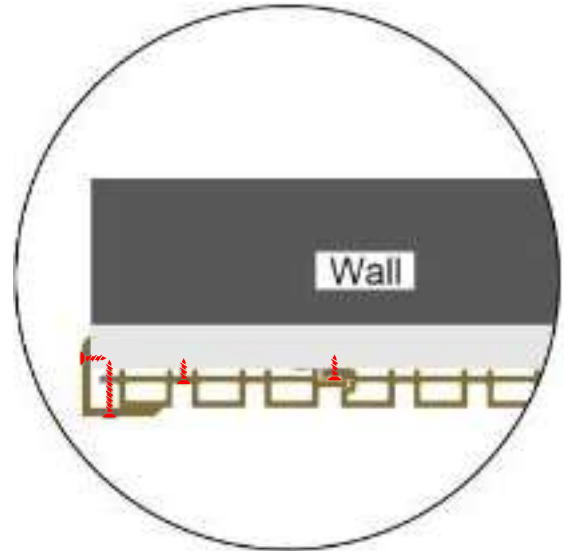

Diagram 11



Detail 12-1